

CITROCASA[®]
PERFORMING FRESHNESS

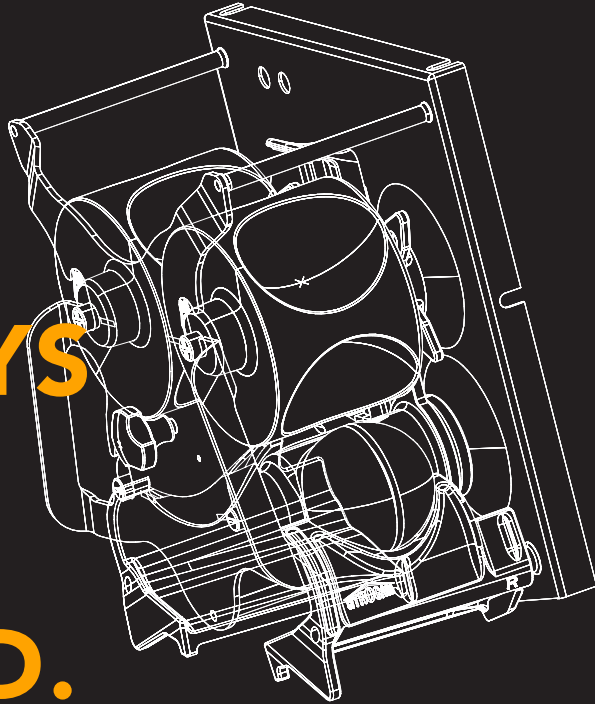

JUICERS

ALWAYS ONE STEP AHEAD.



As a global leading partner of food retailers and gastronomic sector, we always think one step ahead. In the development of our long lasting premium juicers we do not compromise. And we never stop. Always a little better. Always a little more efficient, a little more sustainable. To live up our own ambitious standards, that is how we became what we are today: the leading technology when it comes to freshness and innovation.

SO EASY AND UNCONQUERABLE



HYGIENIC



PREMIUM



PROFITABLE



EFFICIENT



100% SAFE



PRACTICAL



HYGIENE

Everyday life can be hard enough as it is, so we face it head on with simplicity. The removable back of the machine is the key component of the 2-Zone-Technology. This makes the Citrocasa juicer quick to disassemble and easy to clean.



TASTE

Cutting rather than ripping: the precise and dynamic cut of the fruit ensures the purity of the juice - no bitterness and essential oils from the orange peel. This guarantees the highest quality and best taste of juice.

SUSTAINABILITY

In order to ensure absolute hygiene and lifespan, all relevant parts of a Citrocasa juicer are made from stainless steel. This means the highest quality of juice, highest standards of hygiene, and excellent value preservation for our clients.



SAFETY

The patented quick lock fixes all positions with a single screw. The press and cutting tools can be taken out in a matter of seconds to clean and put back in just as fast. A magnetic switch ensures that the machine will only run if everything is in one hundred percent the right position.





MACHINES · FRUITS · BOTTLES

THE CITROCASA SOLUTION



Everything from
one source





**SUSTAINABILITY MEETS
INDEPENDENCE**

ECO LINE

STARLIGHT · FANTASTIC ECO · FANTASTIC ECO PLUS

Everything tastes best made fresh. Citrocasa brings this experience back into our daily life, putting real freshness and flavour at your fingertips. The 18 kg oscillating weights heighten the effectiveness of the juicing elements, enabling smooth and fluid motion in the machine even when running without electricity. Ideal for hotels, organic markets, cafés, beach bars or rustic cabins.



STARLIGHT

The basic machine for an easy introduction into the world of Citrocasa.

Dimensions (HxWxD), Weight:
79.5 x 51.5 x 51 cm, 46 kg



FANTASTIC ECO

This machine combines all design and quality features of the Fantastic series with a high-grade manual gearing mechanism.

Dimensions (HxWxD), Weight:
78 x 57.5 x 56 cm, 56 kg



FANTASTIC ECO PLUS

With its big fruit basket and highend manual gearing mechanism, the Eco-Plus offers a hand pressed freshness sensation on the highest level.

Dimensions (HxWxD), Weight:
94.5 x 57.5 x 56.5 cm, 67 kg

optional accessories:

countertop installation kit, lemon kit, etc.



REVOLUTIONIZING THE ENJOYMENT OF FRESHNESS

REVOLUTION

PERFORMING FRESHNESS – IN A SMALL PACKAGE

Revolutionizing the enjoyment of freshness without taking over the floor plan. A small machine that offers high performance, quick cleaning and 100% Citrocasa quality are only a few of the revolutionary advantages never seen before from such a small, compact juicer. The Compact line will be a valuable asset to your location and is the perfect solution for smaller spaces with high standards of design and quality.



Revolution

Manual feeding, self-service,
juicing oranges and pomegranates

Oranges per minute	15 (1 l/min)
Feeder capacity	5 – 6 oranges
Dimensions (HxWxD), Weight	77 x 24 x 51.2 cm, 43 kg
Power, Voltage	280 W, 110/230 V
Hopper (optional)	10 kg

optional accessories:

countertop installation kit, fruit basket



PERFORMANCE MEETS
EASE OF USE

FANTASTIC M

PERFORMING FRESHNESS – GOURMET QUALITY WITH NO FUSS

With our Fantastic line, you are sure to satisfy discerning customer tastes. The inspired design, user-friendliness and easy cleaning of all components make these juicers ideal for long-term use. Make a statement with exceptional freshness and quality.



Fantastic M/AS

Manual feeding,
automatic start

Fantastic M/SB

Manual feeding,
self-service

Fantastic iPress

Manual feeding,
self-service,
OneStep-Cleaning,
3.5" touch display

Oranges per minute	30 (2 l/min)
Feeder capacity	3 – 4 oranges
Dimensions (HxWxD), Weight	78 x 38 x 55.5 cm, 44 kg
Power, Voltage	200 W, 110/230 V
Hopper (optional)	13 kg

optional accessories:

fruit basket, lemon kit, countertop installation kit, cabinet, etc.

VARIETY MEETS EFFICIENCY

POMEGRANATE

A symbol of life and fertility. Contains a wealth of organic substances that actively support our immune system.
Revolution and 8000 SB ATS Pomegranate



ORANGE

The classic freshly squeezed juice. The orange is the most common citrus fruit in the world.
All Citrocasa Juicers



more information about
our Frutas Naturales

GRAPEFRUIT

A hybrid between orange and pomelo, this once "forbidden fruit" is growing in popularity.
8000 series



LIME

Lemon's little sister stands out with a stronger aroma.
Fantastic and 8000 series



LEMON

The foundation of any good lemonade – the juicy, tart flesh contains between 3.5–8 citric acid and plenty of vitamin C.
Fantastic and 8000 series





**THE PROVEN STANDARD
FOR SERVING SUPERIOR JUICE**

FANTASTIC F

PERFORMING FRESHNESS – THE HIGHEST QUALITY FOR PURE ENJOYMENT

Whatever your application – be it a restaurant, organic grocery store, deli, fitness center or supermarket – the Fantastic F will fit in perfectly, making your location “Fit for Life”. The compact design with a high-capacity fruit basket provides the best of both worlds. For a fruitful business.



Fantastic F/D
Automatic feeding,
programmable fruit quantity

Fantastic F/SB
Automatic feeding,
self-service

Oranges per minute	30 (2 l/min)
Feeder capacity	17 kg
Dimensions (HxWxD), Weight (without base carriage)	94.5 x 50 x 65.5 cm, 52 kg
Dimensions (HxWxD), Weight (with base carriage)	170 x 50 x 65.5 cm, 85 kg
Power, Voltage	200 W, 110/230 V

optional accessories:

lemon kit, countertop installation kit, cabinet, glass presenter, tray slide, bottle dispenser, shop in shop system, etc.



THE PREMIUM IN SELF-SERVICE AND INNOVATION

FANTASTIC 2.0

PERFORMING FRESHNESS – WE DRIVE INNOVATION BY THINKING AHEAD

We have made it our mission to take our customers' affairs seriously and maintain the closest possible contact with the markets. As a result, we have been able to react quickly, pushing the limits of quality, simplicity and efficiency time and again. The result: two new machines that raise the standards to a new level thanks to new displays, automatic sieve cleansing, the OneStep juicing kit and individual connection possibilities.



Fantastic eXpress

Automatic feeding, self-service, OneStep-Cleaning

Fantastic Connect

Automatic feeding, self-service, One Step Cleaning, interactive

Oranges per minute	30 (2 l/min)
Feeder capacity	17 kg
Dimensions (HxWxD), Weight (without base carriage)	94.5 x 60 x 65.5 cm, 52 kg
Dimensions (HxWxD), Weight (with base carriage)	170 x 60 x 65.5 cm, 85 kg
Power, voltage	200 W, 110/230 V

optional accessories:

lemon kit, countertop installation kit, cabinet, glass presenter, tray slide, bottle dispenser, shop in shop system, etc.



**MAXIMUM PERFORMANCE
AND VARIETY**

8000

PERFORMING FRESHNESS – WHEN YOU CAN GO A STEP FURTHER

We offer solutions with maximum performance and efficiency for the situations when every bit counts. The 8000 series is the key to your success if you manage a large supermarket or hypermarket, or if you are planning to produce fresh juice at a semi-industrial scale.



8000 XB
autom. feeding, programmable,
5l juice tank

8000 SB-ATS
autom. feeding, self-service,
automatic sieve cleaning

8000 SB-ATS Pomegranate
autom. feeding, self-service,
automatic sieve cleaning

Oranges per minute	40 (2.7 l/min)
Feeder capacity	21 kg
Dimensions (HxWxD), Weight (without base carriage)	102 x 67 x 66 cm, 78.5 kg
Dimensions (HxWxD), Weight (with base carriage)	179 x 67.5 x 66 cm, 117 kg
Power, Voltage	280 W, 110/230 V

optional accessories:

lemon kit, big pressing kit, cabinet, glass presenter, bottle dispenser, tray slide, shop in shop system, countertop installation kit etc.



**THE INNOVATIVE SOLUTION
FOR HIGH DEMANDS**

8000 2.0

THE FUTURE OF JUICING TECHNOLOGY AVAILABLE NOW!

Thanks to new digital innovations the 8000 2.0 series will usher in a complete new era of juicing experience and builds an outstanding contribution to every business' success story. Both machines have a self-cleaning fruit sieve (ATS) and a OneStep-Cleaning in record time. In addition to that, the 8000 Connect is web-enabled, has access-points for payment systems, and a 7" touch display.



8000 eXpress

Automatic feeding, self-service,
Automatic sieve cleaning,
OneStep-Cleaning

8000 Connect

Automatic feeding, self-service,
Automatic sieve cleaning,
One Step Cleaning, interactive

Oranges per minute	40 (2.7 l/min)
Feeder capacity	21 kg
Dimensions (HxWxD), Weight (without base carriage)	102 x 67 x 66 cm, 78.5 kg
Dimensions (HxWxD), Weight (with base carriage)	179 x 67.5 x 66 cm, 117 kg
Power, Voltage	280 W, 110/230 V

optional accessories:

lemon kit, big pressing kit, cabinet, glass presenter, bottle dispenser, tray slide, shop in shop system, countertop installation kit etc.

EVERYTHING CLOSE AT HAND AND READY TO USE



1 Bottle dispenser

Perfectly adapted to each bottle size. Can be mounted on the left- or right-hand side.

2 Glass tray

For perfect presentation at a buffet. Can be mounted on the left- or right-hand side.

3 Cabinet

The stainless steel cabinet features a built-in waste container.

More information at our website



CUSTOM ACCESSORIES FOR EACH JUICER

ADAPT YOUR CITROCASA TO YOUR INDIVIDUAL NEEDS.

As varied as our machines and their potential applications are, there is no shortage of ways to adapt your Citrocasa to your specific requirements. From the elegant fruit basket to various juicing elements and the modular juice island concept, we offer a comprehensive array of accessories for you to optimize your business with fresh elements.

Small Pressing Kit



Large Pressing Kit



Fruit baskets

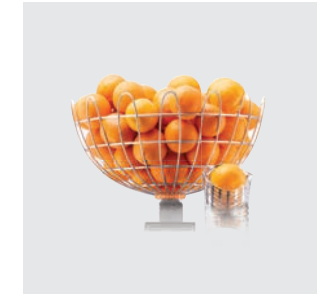

Crushed ice cabinet



Double cabinet



Countertop installation kit



Additional accessories

- Individual pedestals and distance adapters for small, medium and large glasses and bottles
- Rectangular waste containers for up to 30 % increase in capacity
- Cover for the fruit basket for improved safety and hygiene
- Display refrigerator for storing and presenting pre-squeezed juices

FEEDING

MANUAL



COMPACT

Revolution



MEDIUM

Fantastic M/AS

Fantastic M/SB



ECO

Fantastic Eco

Starlight

FEEDING

AUTOMATIC



HIGH

Fantastic F/D

Fantastic F/SB



HIGH 2.0

Fantastic eXpress

Fantastic Connect



ECO

Fantastic Eco Plus



HEAVY DUTY

8000 XB, 8000 SB-ATS, 8000 SB-ATS Pome,
8000 eXpress, 8000 Connect

**MORE
DETAILS
ABOUT OUR
JUICERS.**



citrocasa.com/en/products/juicers

FRESH ORANGE JUICE 365 DAYS A YEAR

The best juice only comes from the best oranges. With that in mind, it is easy to see that the whole package needs to meet the same high standards. Citrocasa sees itself as a pioneer in this regard. The program we have developed to deliver the best quality oranges 365 days a year is a true challenge for everyone involved. But we use everything in our power to guarantee a glass of fresh orange juice. That's why we are able to provide a complete worryfree package, from the machine to oranges and bottles. All that is left for you and your customers is to enjoy the freshness.



CULTIVATION

Strict criteria for selecting suppliers and farmland.



GROWTH

Watering based on existing stock, fruit volume and precipitation.



RIPENESS

Complete development of nutrients, with ripening on the tree.



HARVEST

The ripe fruits are cut from the tree with care and by hand.



LOGISTICS

Cool temperatures and speed are vital to ensure fruit freshness.



FRUIT JUICE

All this combined with Citrocasa machine technology results in the best juice.



100% RECYCLED 100% SUSTAINABLE

RECYCLED PET FOR INCREASED SUSTAINABILITY

- An environmentally conscious solution, these bottles consist 100% of recycled PET bottles.
- A bottle opening optimized for drinking ensures fuss-free enjoyment on the go
- The resilient shape with a flexible base provides increased safety
- Pleasant to hold thanks to the ergonomic shape
- Available in the sizes: 0.25 l / 0.33 l / 0.5 l / 1.0 l

DOING THE RIGHT THING IS IN OUR NATURE.

Our goal is to avoid producing any new plastic waste. No new PET is produced for our bottles, since only 100% recycled PET is used. That way, we help to protect valuable resources.

ALWAYS SETTING NEW GOALS.

We want to protect natural resources and surpass our high quality standards time and again. Our new rPET bottles help us do both – conserve raw materials and provide the ideal material properties for the best quality juice

LIVING SUSTAINABILITY IN ALL AREAS.

That means building sustainable and long-lasting machines, realizing a responsible concept for our Frutas Naturales and – last but not least – establishing sustainability as our guiding principle in packaging as well, with the launch of our rPET bottles made of 100% recycled material.

CITROCASA®

PERFORMING FRESHNESS

